

# Hydration Nation:

Master the Art of Staying Hydrated

Kelsi Buckley, MS, RD, CSOWM



# What words or phrases come to mind when you think about hydration?



Join by Web [PollEv.com/nataliedaher637](https://PollEv.com/nataliedaher637)



< #4 Hydration

Visual settings

Edit

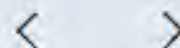

When poll is active respond at [PollEv.com/nataliedaher637](https://PollEv.com/nataliedaher637)



What words or phrases come to mind when you think about hydration?

Loading...

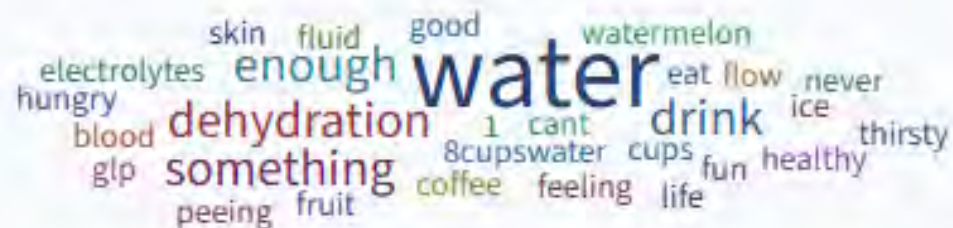



# Why Hydration Matters

---

- Essential for bodily functions
- Regulates body temperature
- Supports physical performance
- Cognitive function
- Prevents dehydration related health issues
- Aids in weight management
- Promotes healthy skin
- Supports joint health
- Facilitates nutrition transport
- Boosts immune function

# Recognizing Dehydration

---

- Feeling thirsty
- Dark yellow urine
- Dry mouth
- Feeling tired
- Dizziness or lightheadedness
- Headache
- Less urination



# Daily Hydration Needs

---

- 8x8 Rule – Good starting point!

Institute of Medicine  
Recommends:

- Men: About 3.7 liters (~13 cups)
- Women: About 2.7 Liters (~9 cups)
- Includes all fluids, not just water

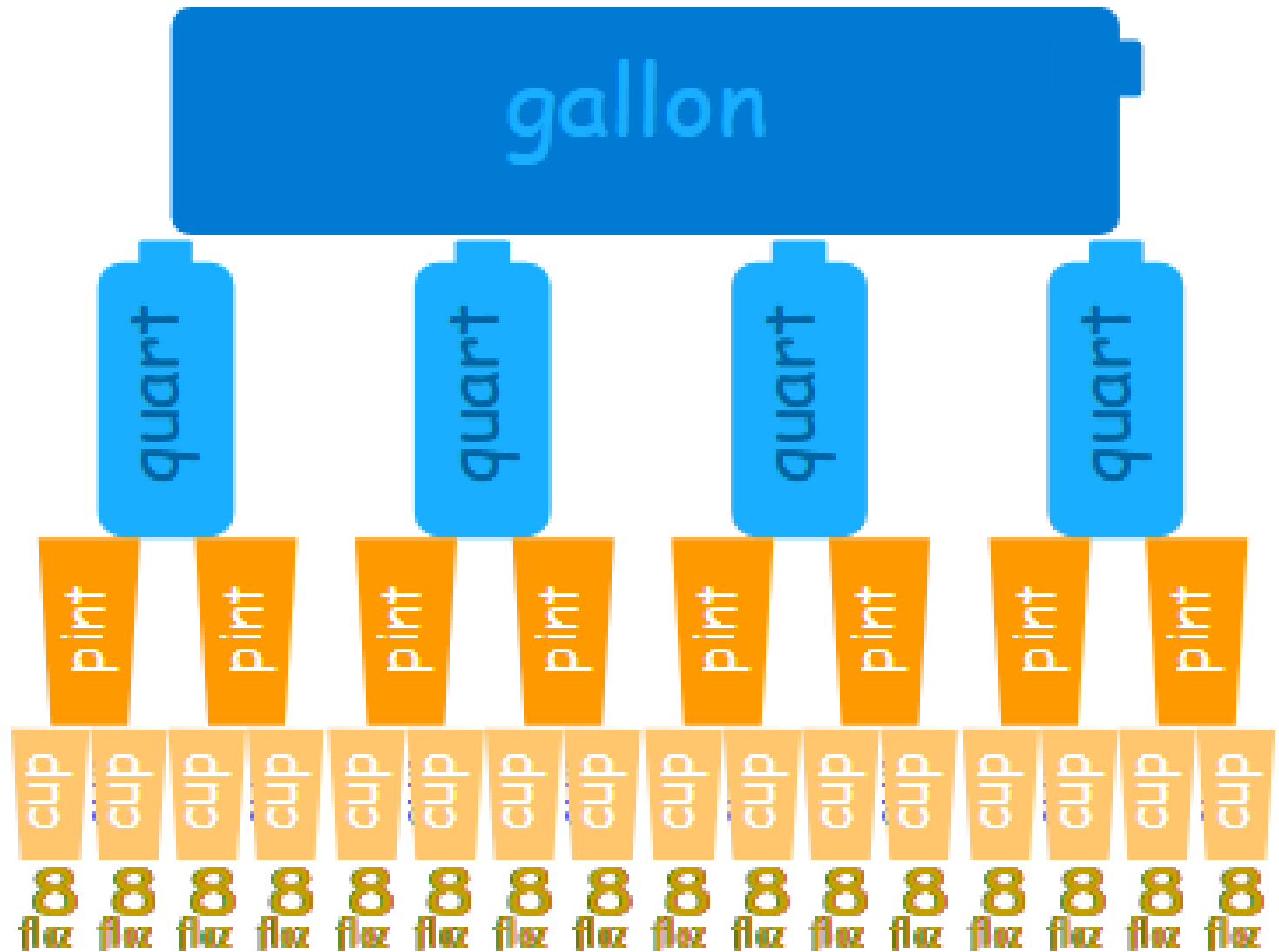

# Sources of Hydration

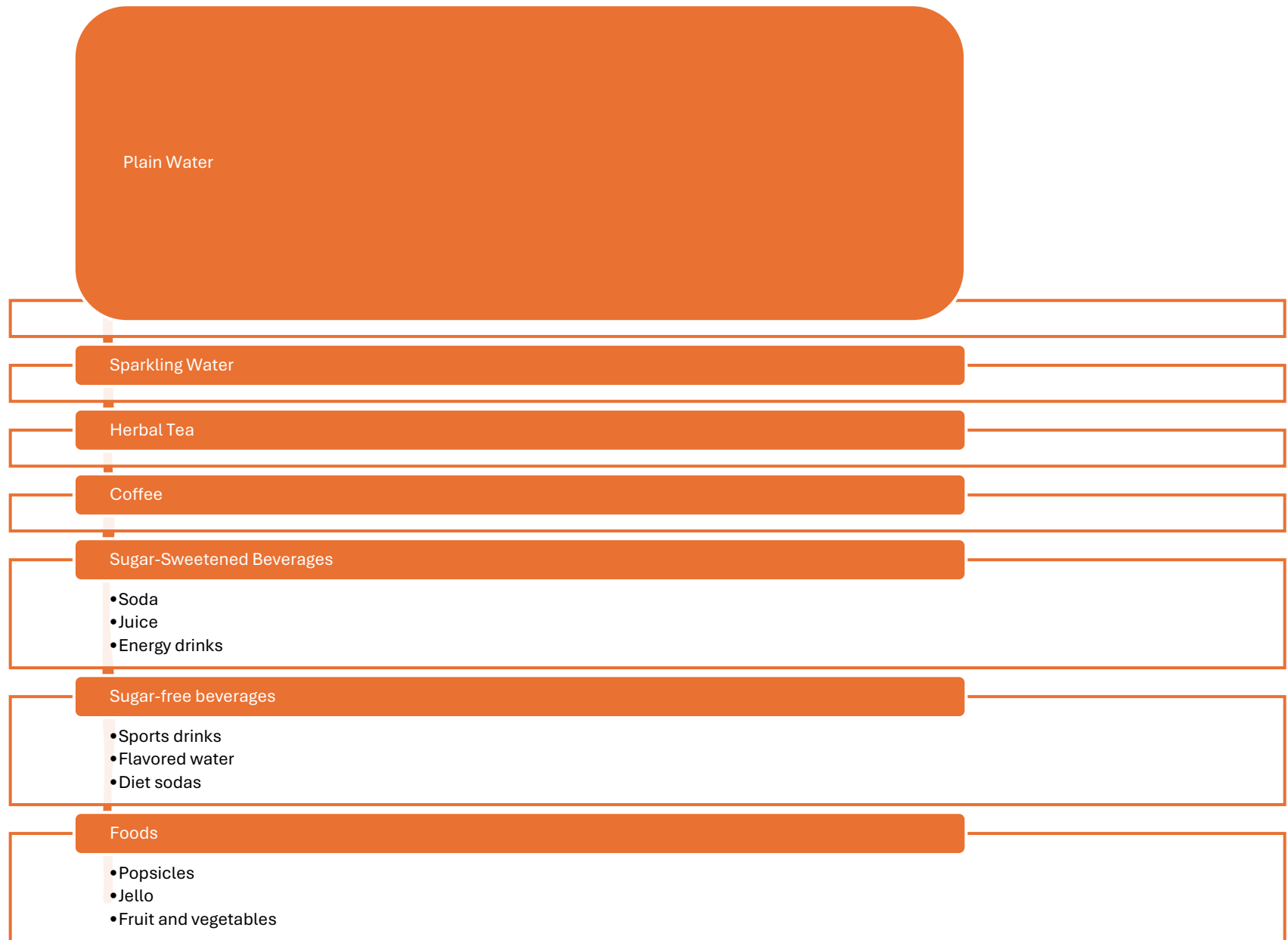

# Sparkling Water

- Carbonation itself does not significantly alter hydrating properties
- Avoid brands with added sugars or high sodium levels



# Coffee and Tea

---

- Diuretic effects
- Avoid adding high fat/sugar additives such as creamer, half and half, sugar, etc.
- Consume caffeine in moderation



# Diet Soda

---

- Water Content
- May contain caffeine
- Health Considerations
- Increased cravings for sweets
- Dental Health





## Sugar-Sweetened Beverages

- 🍷 High in calories
- 📈 Increased blood sugar levels
- 🍏 Limited nutritional value

# Electrolyte Beverages

---

- What's in them?
- When to use them?
- How often should I drink them?
- What's the alternative?



# Hydration From Food

---

- Fruit
- Vegetables
- Popsicles
- Jello

**Complement, Not Replace**



# Practical Tips for Staying Hydrated

---

- Carry a water bottle
- Set reminders
- Drink water before meals
- Track your intake
- Limit caffeine and alcohol
- Hydrate during exercise
- Use a straw
- Make it a routine





# Hydrating and Fun

---

- Infused water – add slices of fruits and herbs or use products like True Citrus
- Flavor Enhancing products – Crystal light, Mio, etc
- Herbal iced tea – brew herbal teas (hibiscus, chamomile or peppermint) and chill, add fresh fruits or herbs for extra flavor
- Coconut water – try infusing with fruit!
- Flavored herbal water – steep herbs like rosemary or thyme in hot water then chill

# Watermelon Basil Splash

---

## Ingredients:

- 1 cup Watermelon (cubed)
- 4-6 Basil leaves
- Lime juice
- Sparkling water

Instructions: Blend the watermelon and basil together, then combine with sparkling water, ice and a splash of lime juice



# Berry Hydrating Slushie

---

Ingredients: (Makes 2)

- 16 oz Coconut water, frozen into ice cubes
- 1 cup frozen berries

Directions:

Mix frozen berries and coconut water ice cubes together in blender and enjoy!



**What is the most important takeaway you learned about hydration today?**



Join by Web [PollEv.com/nataliedaher637](https://PollEv.com/nataliedaher637)



< #4 Hydration



Visual settings



Edit



Join by Web [PollEv.com/nataliedaher637](https://PollEv.com/nataliedaher637)



What is the most important takeaway you learned about hydration today?

The recommended daily water intake



SEE MORE

# Thank you!

Next *Nourish to Flourish* webinar on August 20<sup>th</sup>  
“Get Moving to Energize your Body and Mind”

